

Proposed New Village Store Main Road,
SPILSBY

SINCE 1842
Willsons

PROPERTY PROFESSIONALS

£250 PCM

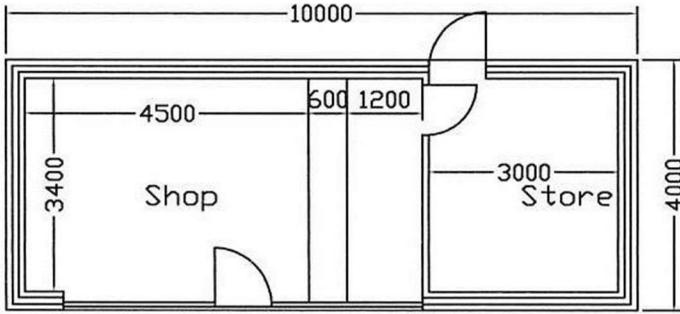

Existing Ground Floor Layout 1:100

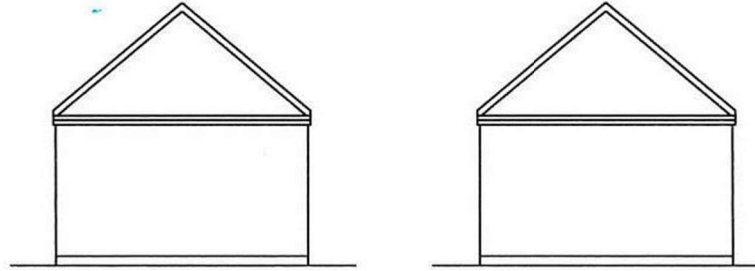

Proposed Side Elevations 1:100

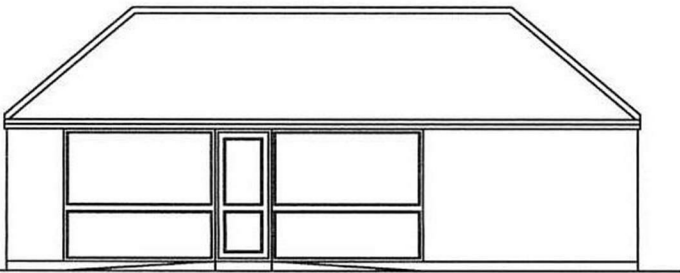

Proposed Front Elevation 1:100

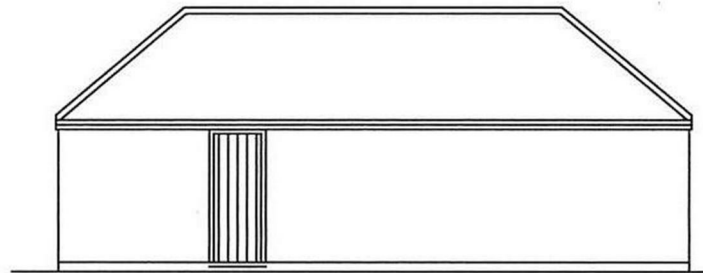

Proposed Rear Elevation 1:100



- Brand New Retail Unit
- Available on a new lease with terms to be agreed
- Village Location
- On the site of the former village store
- Car Parking

16 Alghitha Road, Skegness, Lincolnshire, PE25 2AG
T. 01754 896100 | E. skegness@willsons-property.co.uk
<https://www.willsons-property.co.uk>

ESTATE AGENTS | RENTALS | AGRICULTURAL | AUCTIONEERS | VALUERS





"AGENT COMMENT"

A unique opportunity to lease a brand new detached retail unit situated in the grounds of the former village store in the rural village of Little Steeping. The premises is available on a new lease with terms to be agreed. The property comprises a retail area with a store and parking area.

Retail Area

20'8" x 11'2" (6.30 x 3.40)

With door and window to front, door to:-

Store

11'2" x 9'10" (3.40 x 3.00)

With external door.

Layout:

The new store will be constructed to final fit out stage and the internal (and external subject to planning permission) layouts can be varied to the lessees design and layout preferences according to the proposed usage. Trade fixtures and fittings will be the responsibility of the lessee. Other trade or business uses a possibility subject to planning permission.

Lease:

The property will be let on a new 7/9 year lease with 3 yearly rent reviews and break clauses to be agreed. Initial rent of £250 per calendar month. Prospective tenants will be asked to provide 2 trade references together with a bank reference.

Viewing:

Viewing is strictly by appointment with the Skegness office at the address shown below. View our properties online at: www.willsons-property.co.uk, www.rightmove.co.uk & www.onthemarket.com

Directions:

To find the property from Spilsby, proceed along the B1195 east towards Wainfleet. Before entering the village of Great Steeping turn right towards Little Steeping where the property can be found on the right hand side after the Eaves public house.



Viewing Care should be taken when viewing; you enter at your own risk. **Measurements and Photographs** Room sizes and photographs are provided for guidance only and should not be relied upon. **Services** We have not tested any services, heating system or equipment or appliances including fixtures and fittings. **Property condition** Nothing in these particulars should be deemed as a statement that the property is in good structural condition. **Inclusions** only items described in these particulars are intended for inclusion in the price. **General** These details are only a general guide to the property. They have been prepared in good faith and do not form any part of an offer or contract and must not be relied upon as statements or representations of fact. Neither Willsons nor their employees have any authority to make or give any representations or warranties whatsoever in relation to this property.

